

# RENAULT CLIO



November 2025



# different energy, same love

More Clio than ever after 30 years of success, new Renault Clio injects new energy. The overhaul of the Renault identity is reflected in the sportiness of its esprit Alpine version and the sharper brand light. Inside are biobased and recycled materials, comfort and connectivity.



Enjoy a unique driving experience with the 145hp E-Tech full hybrid engine.

**145hp E-Tech full hybrid engine**

**up to 900 km of driving range\***

**esprit Alpine version**

**biobased and recycled materials**

**301L boot volume**

**up to 17 driver-assistance systems**

\* depending on battery charge status and driving style - WLTP data, March 2023.

## a new impetus

Renault Clio unveils a distinctive and stimulating style: enlarged front grille with chrome, new full LED lights at the front and rear, and sculpted sides. The sportiness is expressed in every detail, with the esprit Alpine version and its shadow grey F1® blade.



The Nouvel R diamond logo and the half-diamond daytime running lights accentuate the modernity of the design, providing a bold and distinctive look.



In the esprit Alpine version, the 17" Alpine, F1 inspired wheels enhance the model's sports personality\*.



The esprit Alpine interior stamps its identity, with the blue top-stitching on the upholstery, the embroidered motif on the upper seatback, the aluminium pedal unit and the Alpine door sill. The dashboard and the seats adorned with a French flag badge and the blue/white/red stitching on the steering wheel give a nod to the esprit Alpine DNA.

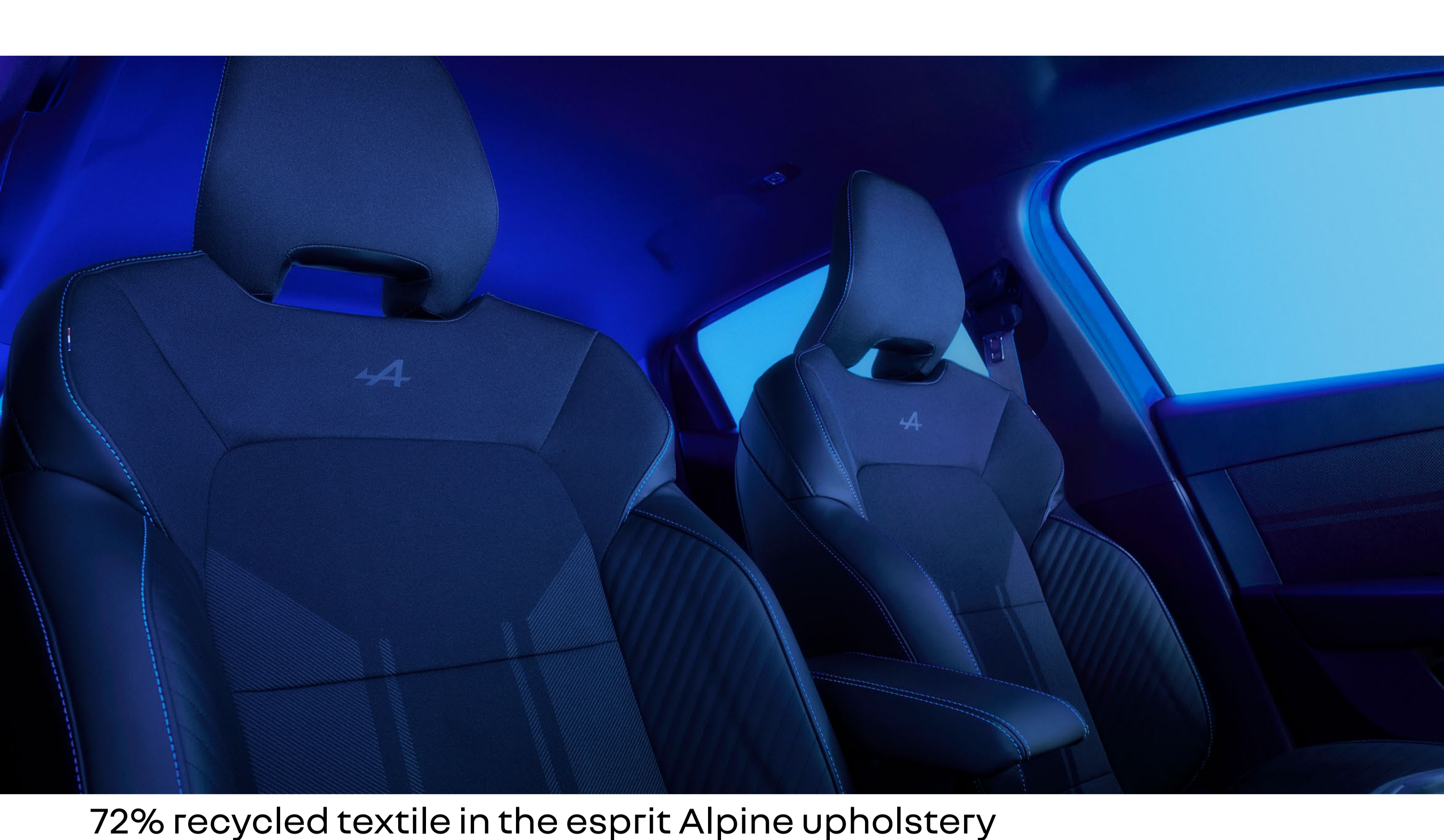

72% recycled textile in the esprit Alpine upholstery



blue/white/red top-stitching on the steering wheel

\*blue centre cap or grey centre cap depending on body colour.

## 02. driving pleasure

# E-Tech full hybrid

E-Tech  
**full hybrid**  
**145 hp**

up to  
**80%**  
electric driving  
in town

from  
**96 g/km**  
CO<sub>2</sub> emissions<sup>(2)</sup>

up to  
**900 km**  
of driving range<sup>(1)</sup>

from  
**4.2L/100 km**  
fuel consumption<sup>(2)</sup>



**In town, the electric driving allows you to achieve up to 40% fuel savings<sup>(3)</sup>. The battery recharges during deceleration and braking.**

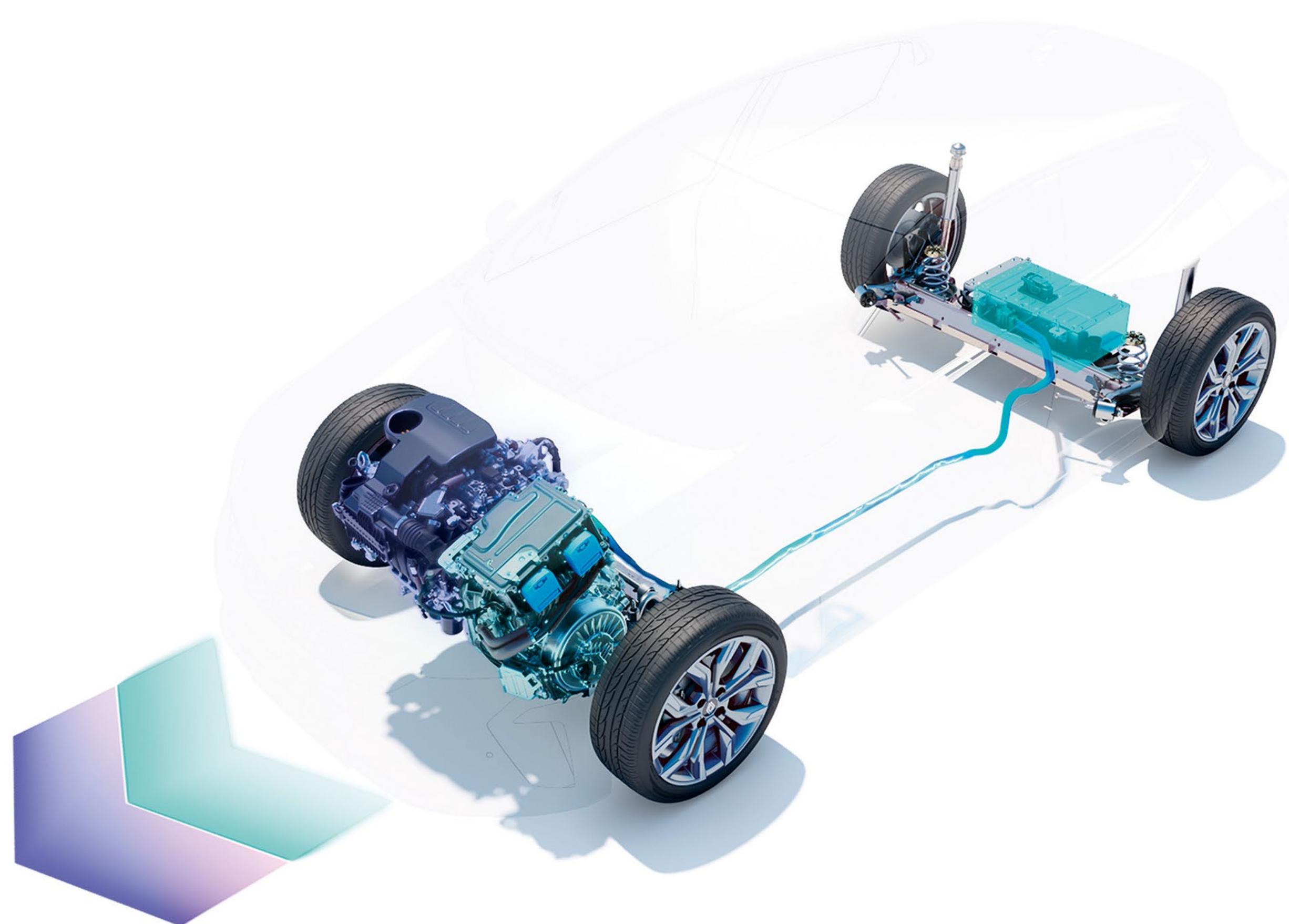

(1) up to 900km range with a full tank, according to WLTP data.

(2) 4.2l/100km of fuel consumption and 96 g to 97 g/km of CO<sub>2</sub> emissions, certified values depending on version / according to WLTP data / UTAC source / March 2023.

(3) for an E-Tech full hybrid engine compared to an internal combustion engine, according to WLTP City protocol / UTAC & IDIADA source / September 2022.

# next-generation comfort

**Take a seat in a contemporary interior featuring coatings made from biobased materials and a steering wheel stamped with the new Renault identity. Personalise the driving experience with the three multi-sense modes.**



## more welcoming than ever

Thanks to its feel for comfort and roominess, the rear provides excellent knee room of 16.5 cm and optimal headroom to accommodate both children and adults.



Enjoy the generous boot volume of 301 L. Adjust the 1/3-2/3 bench seat very easily for available space of up to 1,006 L in the configuration with three seats folded down.



# resolutely connected

New Renault Clio connects you to the remote services you need. Enjoy the easy link connected system and its 9.3" multimedia touch screen<sup>(1)</sup>, with on-board navigation<sup>(4)</sup> and wireless smartphone replication.



The wireless replication compatible with Android Auto™ and Apple CarPlay™ shows all of your apps, playlists, podcasts and calls on the multimedia screen

The customisable 10"<sup>(2)</sup> digital instrument cluster keeps essential driving information in your direct view.



Stay permanently connected thanks to the wireless induction charger<sup>(3)</sup>, located in the central storage space, to recharge your smartphone at any time without having to plug it in.



(1) 7" touchscreen on evolution, 9.3" on esprit Alpine.  
(2) 10" available on esprit Alpine only.  
(3) standard on esprit Alpine version.  
(4) from evolution.

Android Auto™ is a trademark of Google Inc.  
Apple CarPlay™ is a trademark of Apple Inc.

## 05. advanced driver-assistance systems



# up to 17\* advanced driver-assistance systems

As part of the human first program, new Renault Clio offers up to 17\* advanced and innovative driver-assistance systems.

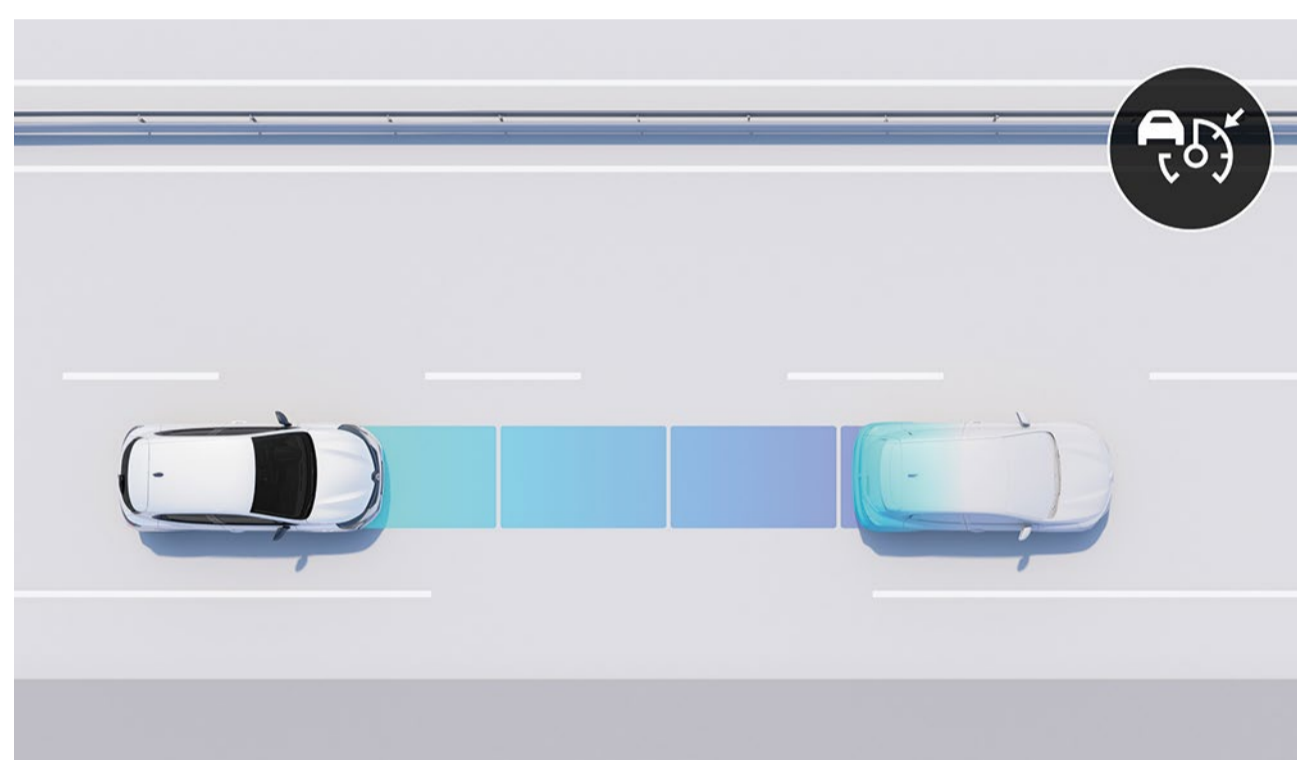

**adaptive cruise control**  
The system keeps a safe following distance from the vehicle in front of you. It activates the brakes if you get too close and accelerates when the road is clear again.

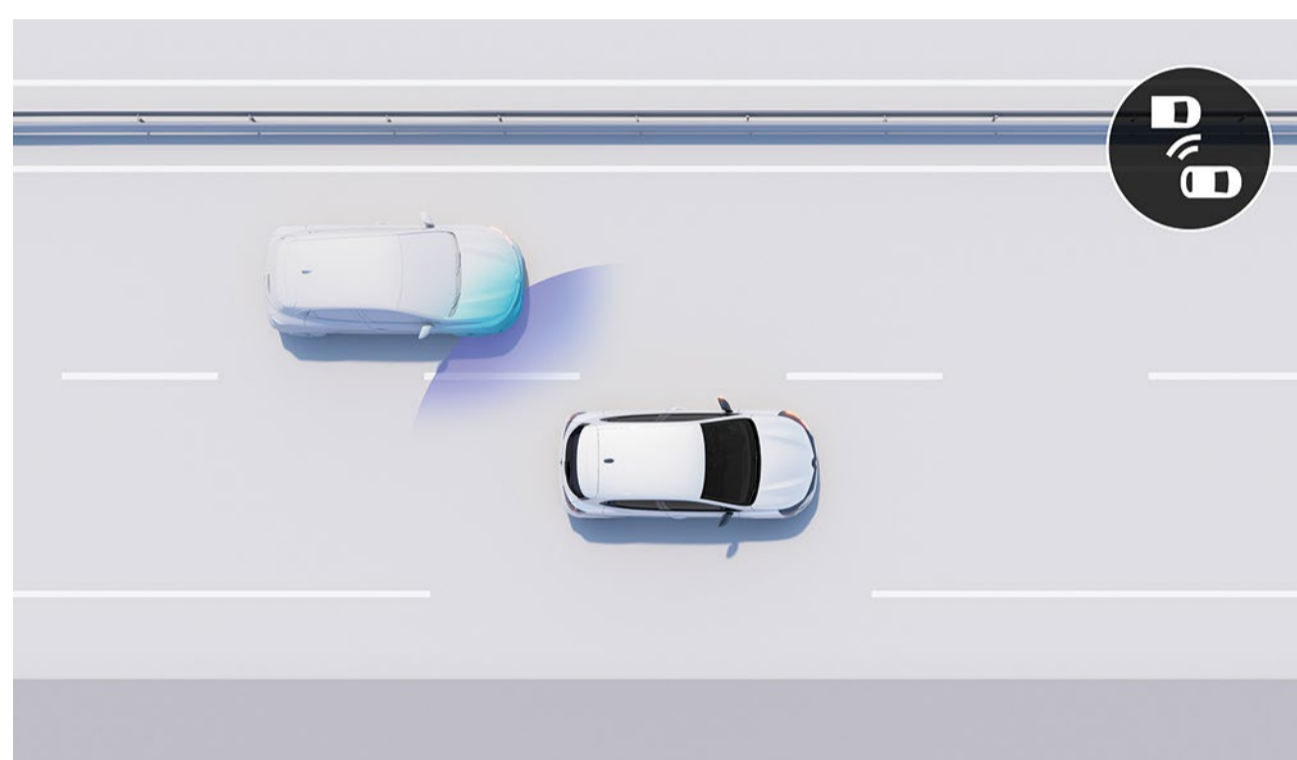

**blind spot warning**  
Enabled at speeds over 9mph, this system uses warning lights to alert you to the presence of vehicles that are not visible in your field of vision.

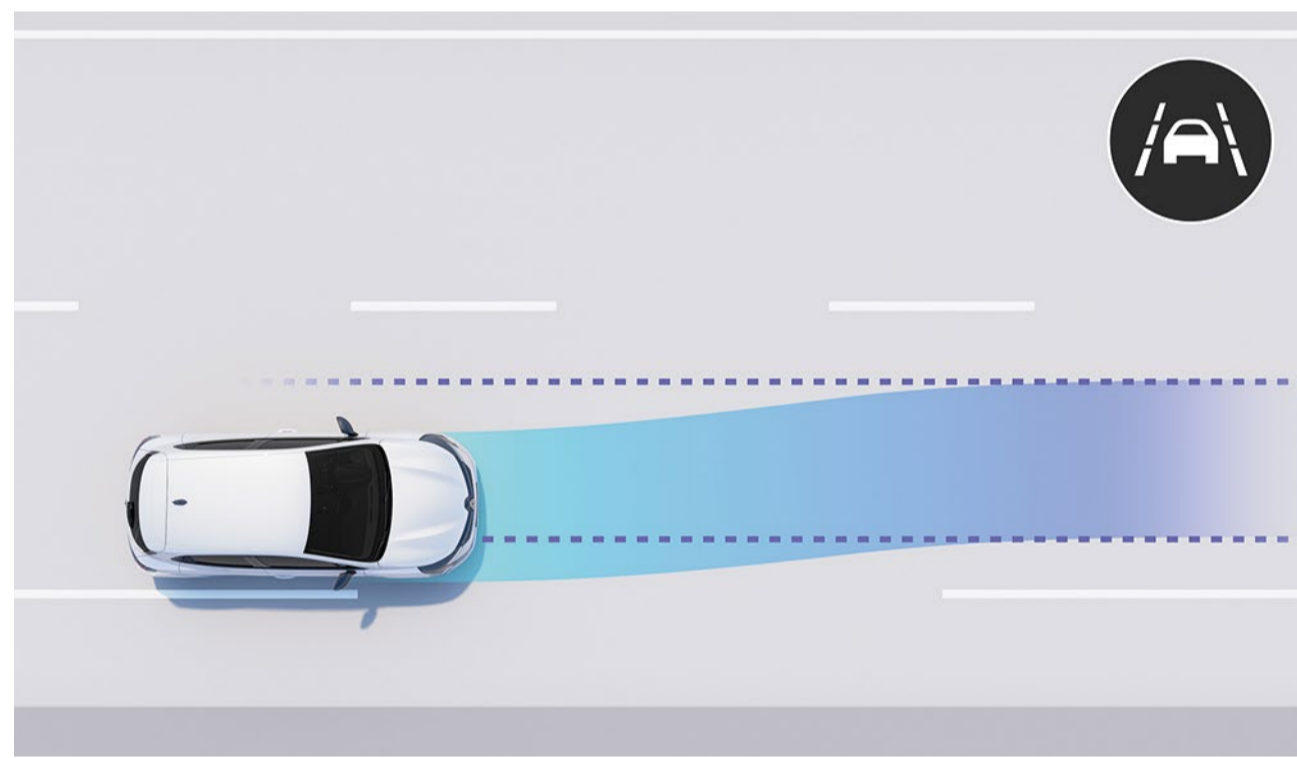

**lane keeping assist**  
This system corrects the angle of the steering wheel, returning the vehicle to its lane unless you have indicated.



**automatic emergency braking**  
Warns the driver of an imminent risk of frontal collision with a stationary vehicle, at low speeds. Triggers automatic emergency braking to avoid or mitigate a collision.

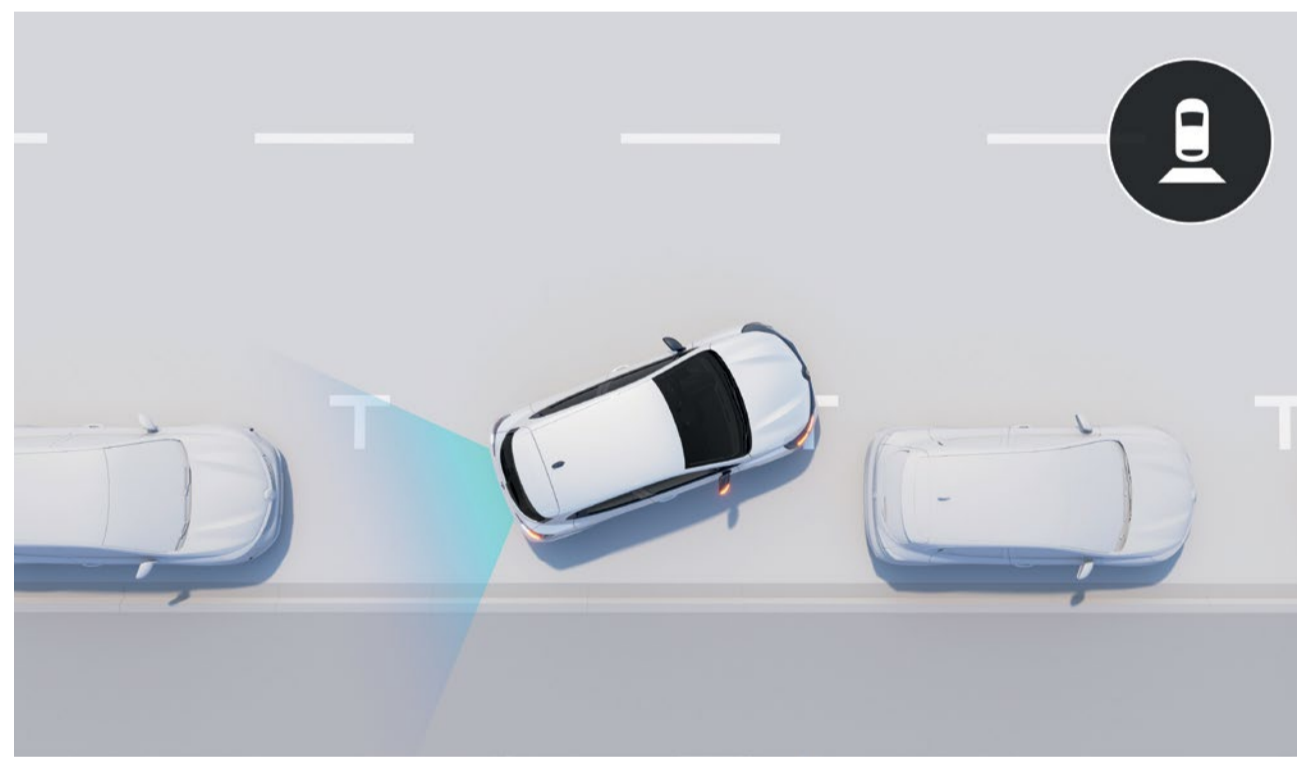

**rear view camera**  
This system provides a rear view on the screen when you engage the reverse gear. Superimposed outlines make your manoeuvres easier and safer.



**rear cross traffic alert**  
When reversing, the system warns you of a risk of collision with a vehicle.

### driver-assistance systems

- hill start assist
- safe following distance warning
- speed limiter
- cruise control
- adaptive cruise control

### park assist systems

- front parking sensors
- rear parking sensors
- side parking sensors
- rear view camera

### safety

- lane departure warning
- lane keeping assist
- blind spot warning
- rear cross parking alert
- automatic main-beam/dipped headlights activation
- automatic emergency braking
- road sign recognition
- road sign recognition and speeding alert

\* up to 17 adas features across the range. see equipment list to see what is available as standard by version.

## 06. customisation

# colours



**glacier white (nmp)**



**shadow grey (mp)**



**pearl black (mp)**



**valencia orange (mp)**



**iron blue (mp)**



**ceramic grey (p)**

nmp: non-metallic paint (FOC colour).  
mp: metallic paint.  
p: pearlescent

## 06. customisation

# interior trims



### evolution

- 7" touchscreen with easy link and built in navigation
- automatic climate control
- 16" boa vista alloy wheels



### esprit Alpine (evolution+)

- 10" digital driver display
- 9.3" touch screen with easy link and built in nav
- esprit Alpine enveloping fabric seats with sustainable fabric synthetic leather and Alpine detailing
- heated seats and heated steering wheel
- adaptive cruise control, blind spot warning and rear cross traffic alert

## 06. customisation

# upholstery

evolution

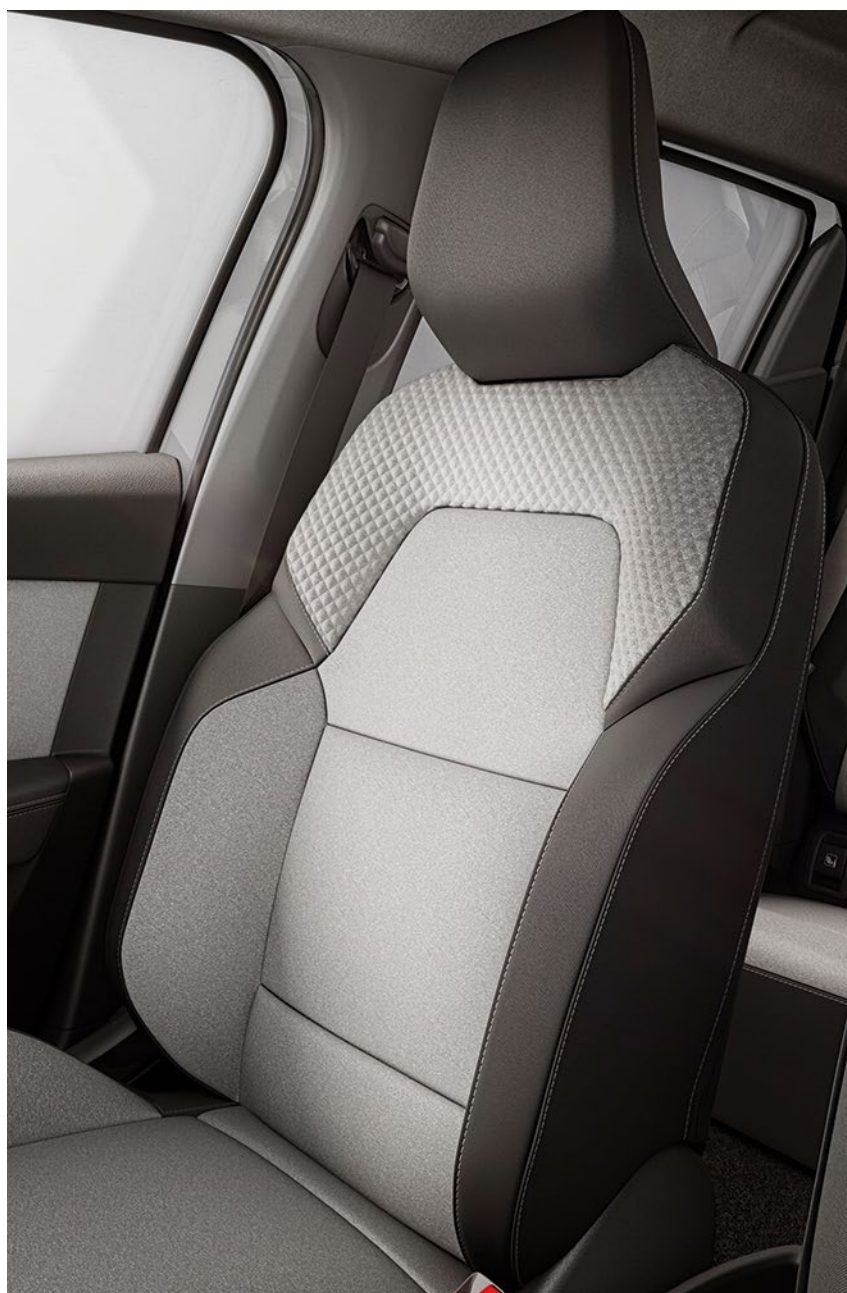

grey textile upholstery  
with 3D pattern

esprit Alpine



grey textile upholstery  
and black textured  
coated textile with blue  
top-stitching

# wheel rims



16" boa vista black  
diamond-cut alloy wheel  
(evolution)



17" esprit Alpine diamond  
cut alloy (esprit Alpine)

# accessories



### underbody lighting

This lighting means no more getting lost in a poorly lit car park. You will be able to easily identify your vehicle as you approach it, as the LED ambient underbody lighting and the dipped headlights turn on automatically.



### esprit Alpine premium floor mats

Reaffirm the sporty look of your new Clio in the esprit Alpine version with a distinctive signature featuring the exclusive marking of the Alpine logo on the driver's and front passenger's side mats, the premium quality carpet and the blue top-stitching.



### semi-electric retractable towbar pack

Do you want your vehicle to look its best? The innovative Renault semi-electric towbar system allows you to deploy this in just a few seconds. When folded, it becomes invisible and perfectly protects the design of your vehicle.



### quickfix roof bars

Quick and easy to install completely safely and without any tools needed, thanks to the innovative quickfix attachment system. Ideal for adding a bicycle rack, ski rack or roof box and increasing your vehicle's carrying capacity.



### rear view camera

Add this rear view camera to your vehicle's multimedia screen, giving you greater comfort when manoeuvring. When in reverse gear you'll see the area behind your vehicle directly on the screen.

## 06. customisation

# E-Tech engine

### E-Tech full hybrid 145

---

**fuel**

---

unleaded petrol (E10) + full hybrid

---

**maximum power (hp)/revs (rpm)**

---

145/5,600

---

**maximum torque (Nm)/revs (rpm) engine and e-motor**

---

144/3,200-3,600

---

205

---

**battery (kWh)**

---

1.2

---

**kerb weight (kg)**

---

1,323

\* unleaded petrol (E10).

# dimensions and volumes

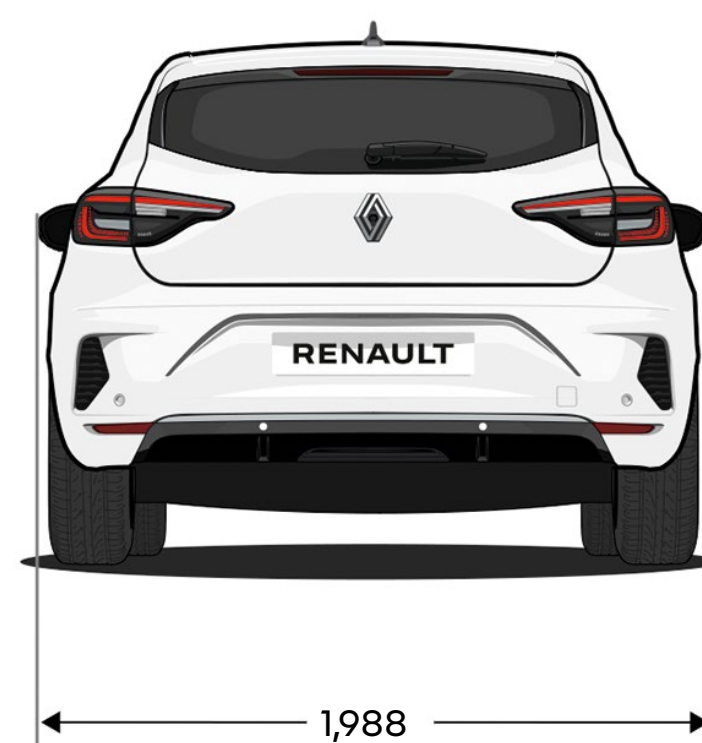
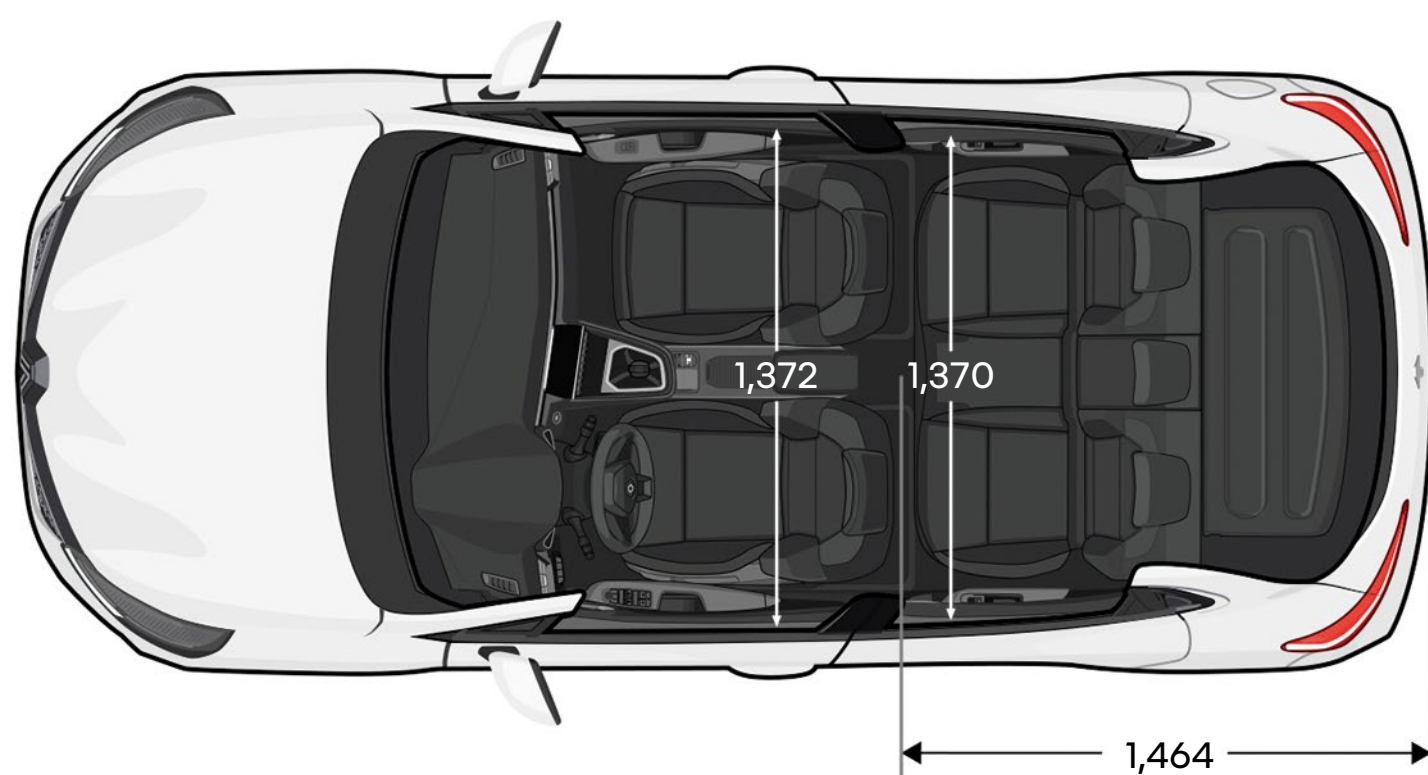
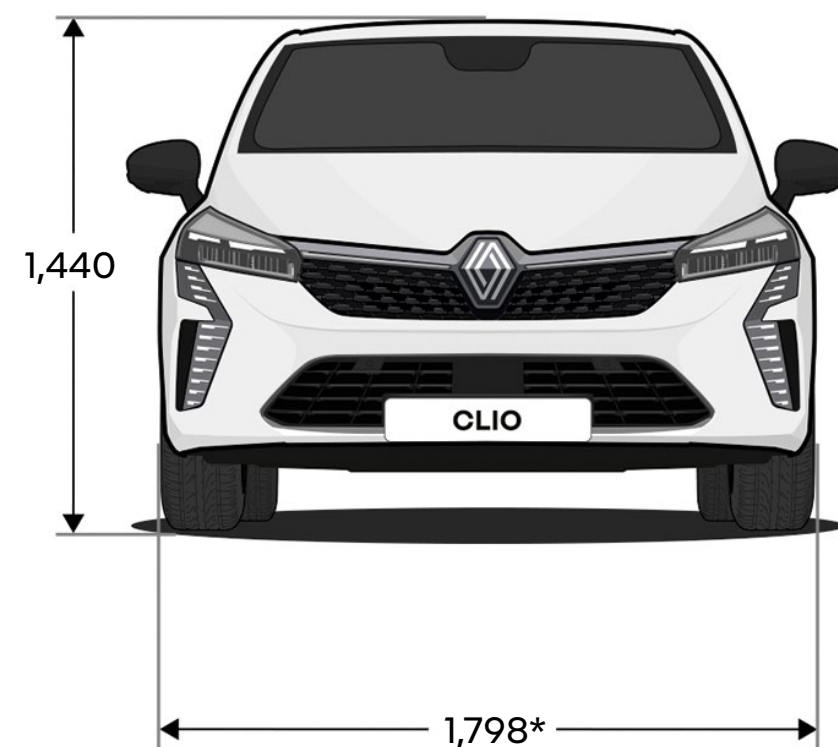
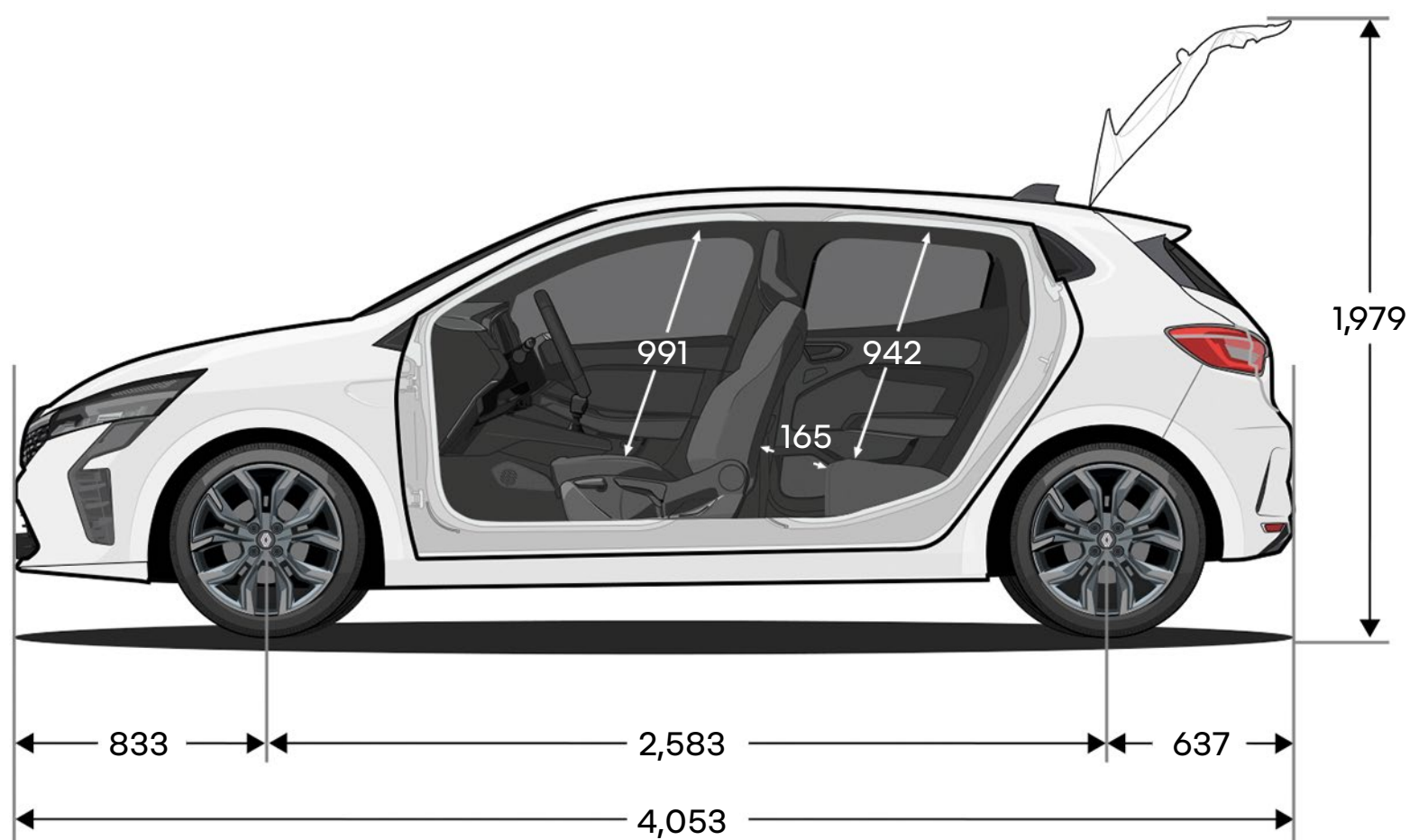

## boot volume (litres)

## E-Tech full hybrid

max with tyre inflation kit

301

max bench seat folded down with tyre inflation kit

1,006

\* door mirrors folded.  
dimensions in (mm).

# **Renault care service**

**We are always by your side to make your driving experience easier and save you time with the maintenance of your Renault: online quotes and appointments, fixed price packages, maintenance contracts, insurance and assistance, personalised My Renault programme, etc. Take advantage of our simple and fast solutions tailored to your needs.**



Every precaution has been taken to ensure that the contents of this brochure were accurate and up-to-date at the time of its release. This document has been created using pre-production and prototype models. In line with its policy of continuous product improvement, Renault reserves the right to modify the specifications, vehicles and accessories described and featured at any time. Any such modifications are communicated to Renault dealers as quickly as possible. Depending on the country of sale, versions may differ and some equipment may be unavailable (standard, optional or accessories). Please contact your local dealer for the latest information. For reasons to do with the medium, the colours featured in this document may differ slightly from those of the actual paintwork or interior trim. All rights reserved. Reproduction in any format and by any means of all or part of this brochure is prohibited without prior written authorisation from Renault.

Publicis – photo credits: M. Leuvre, ©Renault Marketing 3D-Commerce – November 2025.

Renault recommends 

