

RENAULT SYMBIOZ



version shown not available in Ireland



technology that reconnects you

The ultimate lifestyle car, Renault Symbioz combines all the advantages of a compact vehicle with those of a family car. The interior is both technologically advanced and comfortable to ensure your well-being, with generous interior space, a solarbay[®] opacifying panoramic sunroof, premium Harman Kardon[®] sound and the openR link multimedia system.



version shown not available in Ireland

When technology meets interior comfort for an enhanced on-board experience.

**solarbay[®]
opacifying
panoramic
sunroof⁽¹⁾**

**openR link
system with
Google built-in⁽²⁾**

**29 advanced
driving-
assistance
systems**

**up to 708 litres⁽³⁾
of boot volume**

**160 hp full hybrid
E-Tech engine**

**up to 1,000 km
of range⁽⁴⁾**

(1) available as an option. (2) Google, Google Play, Google Maps, Waze and other brand names are trademarks of Google LLC. (3) with the mild hybrid engine and bench seat fully forward. (4) with a full tank of petrol according to WLTP data.

interactive menu

01. design

02. on-board experience

03. multimedia

04. interior space

05. driving pleasure

06. safety & security

07. customisation

avant-garde elegance

Its assertive personality defines the exterior style of Renault Symbioz. Its dimensions remain compact to adapt to your needs. With its robust and refined grille with the new Renault identity, satin chrome logo and half-diamond brand light, each element of the design accentuates its charisma.



The radiator grille, made up of micro-diamonds, is adorned with a graphic effect. At the rear, the Symbioz signature emphasises the sharp lines.



The 19" alloy wheels add a powerful look to the silhouette.



esprit Alpine

The Alpine spirit stands out through a number of distinctive features, including the schist grey F1 strip.



Special 19" elixir wheels and Alpine badge on the front wings for more sportiness. On board, upholstery topstitched in Alpine blue with iconic Alpine logo on the seat backs.

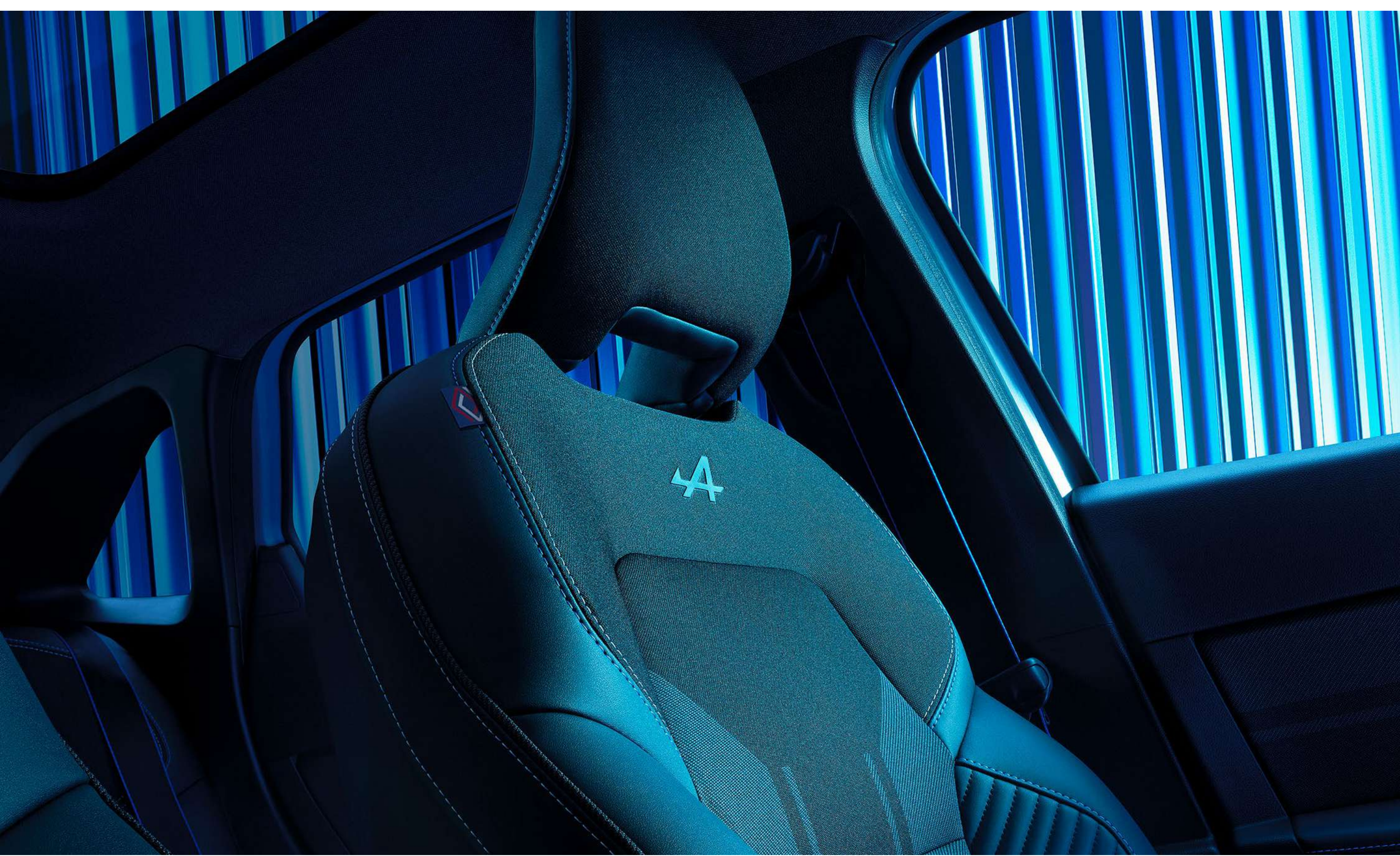

connect with well-being

Take a seat in a high-tech cockpit that enhances driving pleasure. With its steering wheel controls, the dashboard is streamlined and driving is simplified. Every passenger can enjoy the innovative view offered by the solarbay^{®(1)} opacifying panoramic sunroof and the customised sound environment created by Harman Kardon^{®(1)}. Whatever the journey, share the fun with family or friends.



Solarbay[®] technology is voice-activated with Google Assistant⁽²⁾ or manually via a button located on the courtesy light. Adjustable to 4 different opacity configurations, it maintains light and heat comfort on board in both summer and winter.

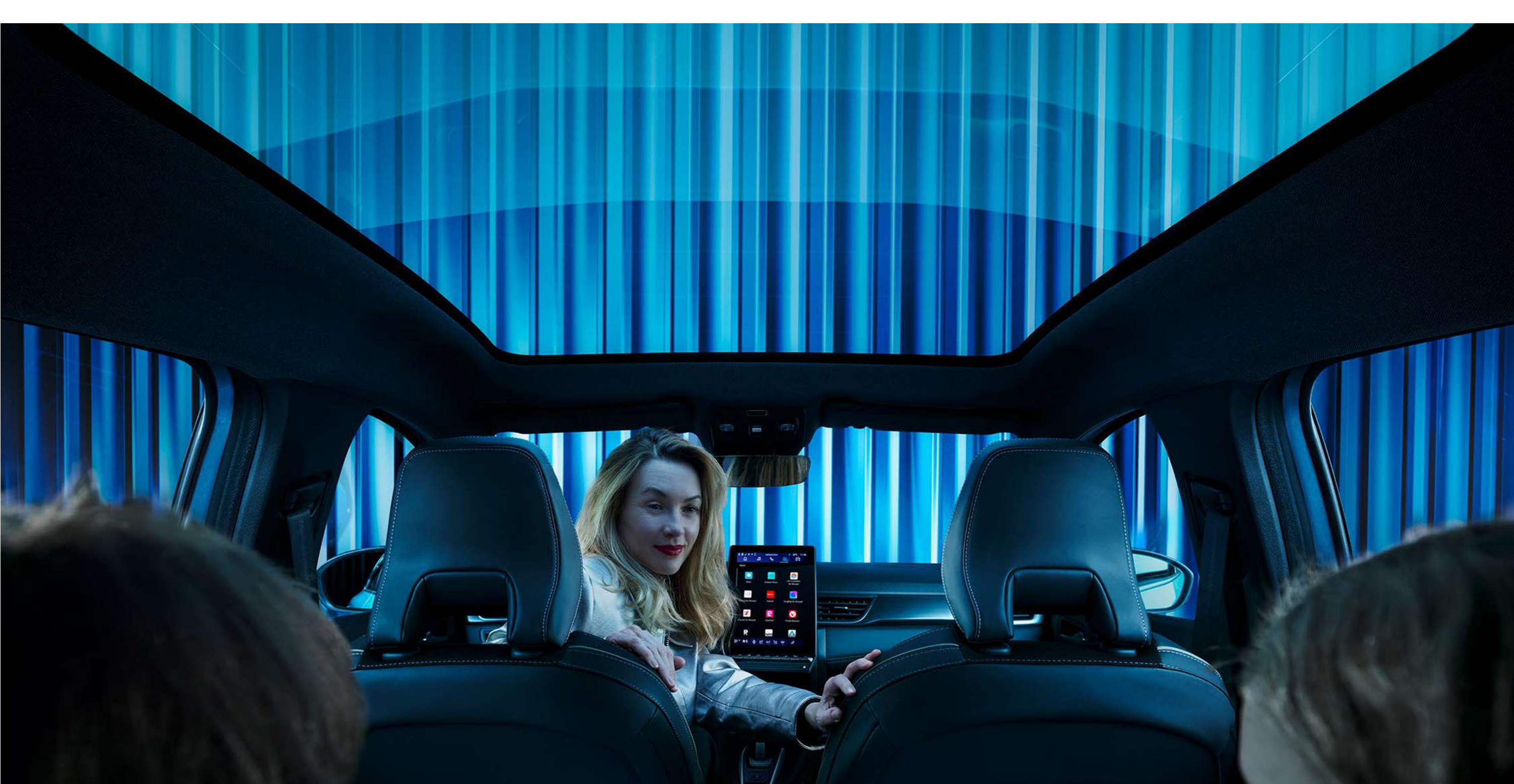

The passenger compartment has an induction charging point. Put your smartphone on it and your device will stay charged wirelessly, without interruption.



(1) standard on iconic esprit Alpine. (2) My Renault, Google Maps and Google Assistant connected services are provided free of charge for 5 years from the date of delivery of your vehicle. Google, Google Play, Google Maps, Waze and other marks are trademarks of Google LLC.

Immerse yourself in the exclusive Harman Kardon® sound experience and enjoy the most beautiful emotions: 9 speakers distributed throughout the cabin and designed to deliver the same sound quality in each seat.

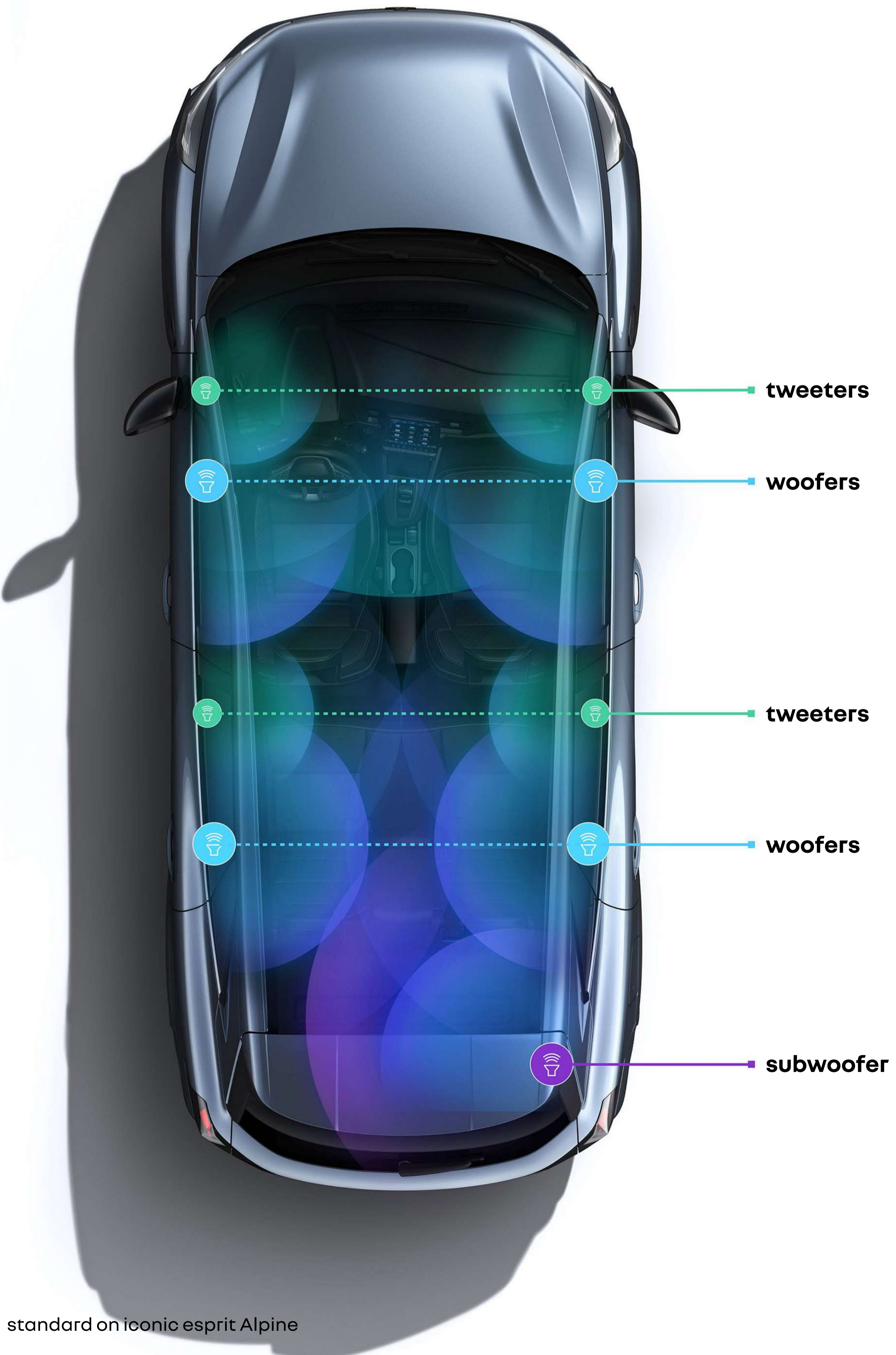

openR link multimedia system with Google built-in

The 10.4" central display and the 10" digital TFT dashboard connect you to the best of technology thanks to the openR link multimedia system with Google built-in⁽¹⁾. Enjoy more than 50 apps for a shared experience.



Google Maps⁽²⁾ provides accurate navigation even if the network goes down, informing you of road closures, changes to the direction of traffic, road works, etc.

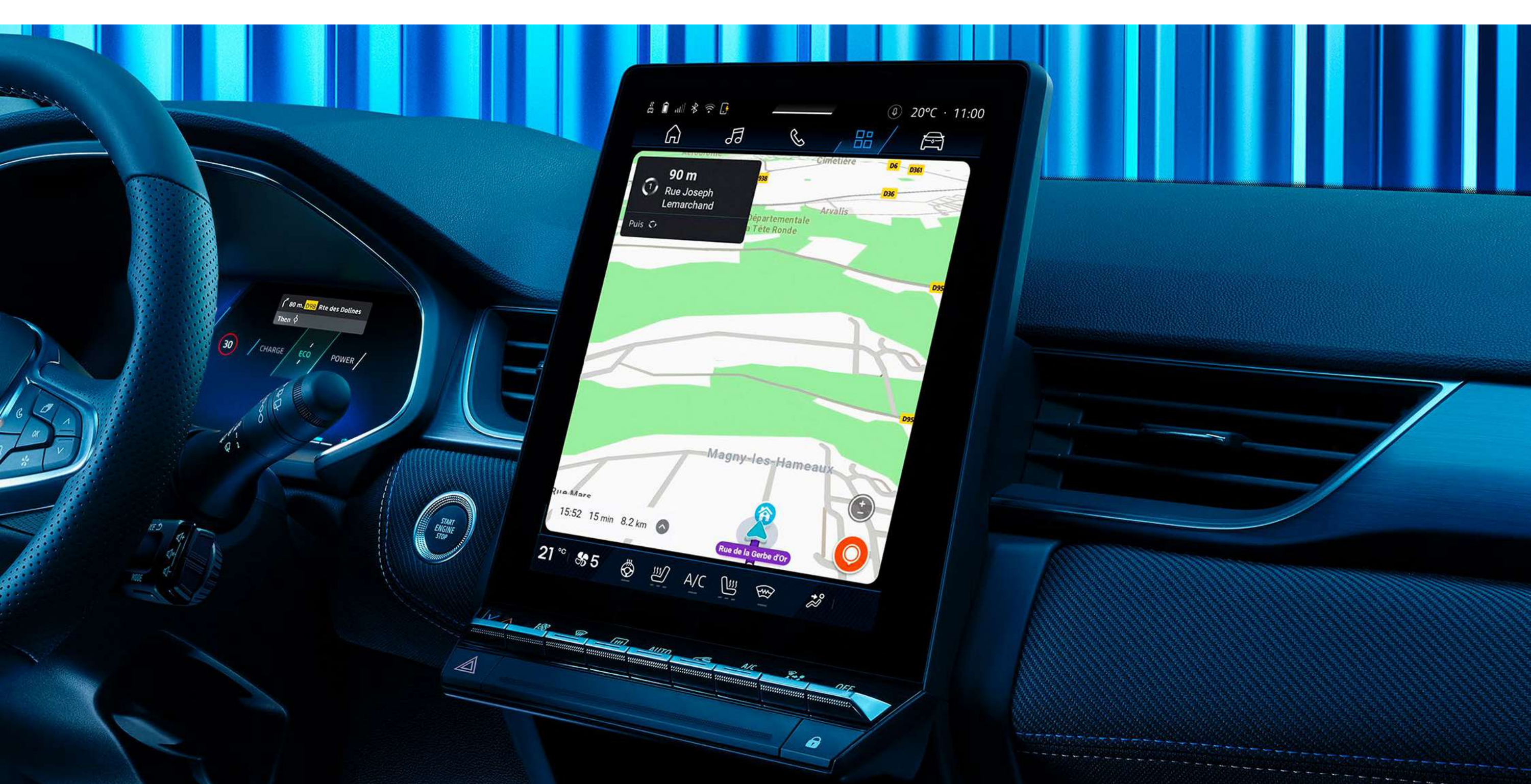

"Hey Google..." Talk to it to plan a trip, change driving mode or adjust the opacity of the solarbay[®] panoramic sunroof. The voice assistant is there for you.



More than 50 applications⁽¹⁾ are available including 11 from Renault partners with Google Play⁽³⁾.

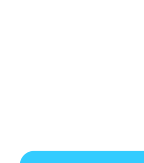
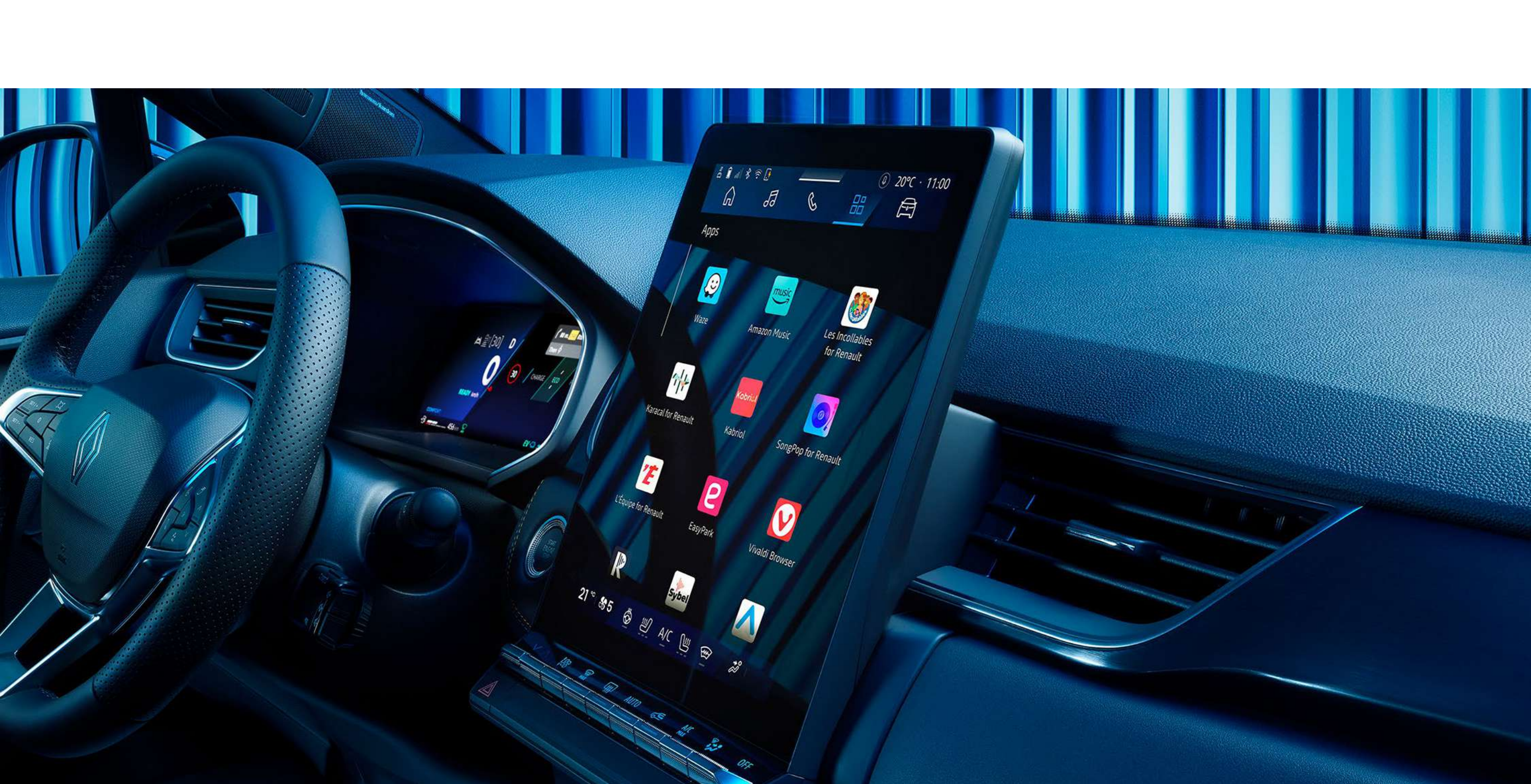

Waze is a community-based navigation app that shares information in real time. Waze gives you more peace of mind.

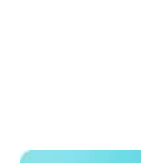

Take the road while listening to playlists, and much more, with **Amazon Music**, included with your Amazon Prime subscription.



Vivaldi browser is an efficient, fast web browser that respects your privacy.



Sybel is a unique platform to find your favourite podcasts, and discover exclusive original creations, audio books, new documentaries, etc.

(1) Google, Google Play, Google Maps, Waze and other brand names are trademarks of Google LLC.
(2) My Renault, Google Maps and Google Assistant connected services are provided free of charge for 5 years from the date of delivery of your vehicle. (3) The use of applications downloaded from Google Play requires a dedicated data package. To use these apps, share your phone's connection with your Renault. You can also take out an offer with our partner, Orange. Google, Google Play, Google Maps are available from techno version.

the space adapts to you

The spacious passenger compartment has the ideal dimensions and modular design for perfect versatility, with electric front seats⁽¹⁾, 22 cm of legroom in the rear and a folding and sliding rear bench seat.



With the rear bench seat folded down, you have a total volume of 1,682 litres⁽²⁾ to carry your luggage, groceries or equipment. The practical hands-free system allows the tailgate to be opened with one foot movement.

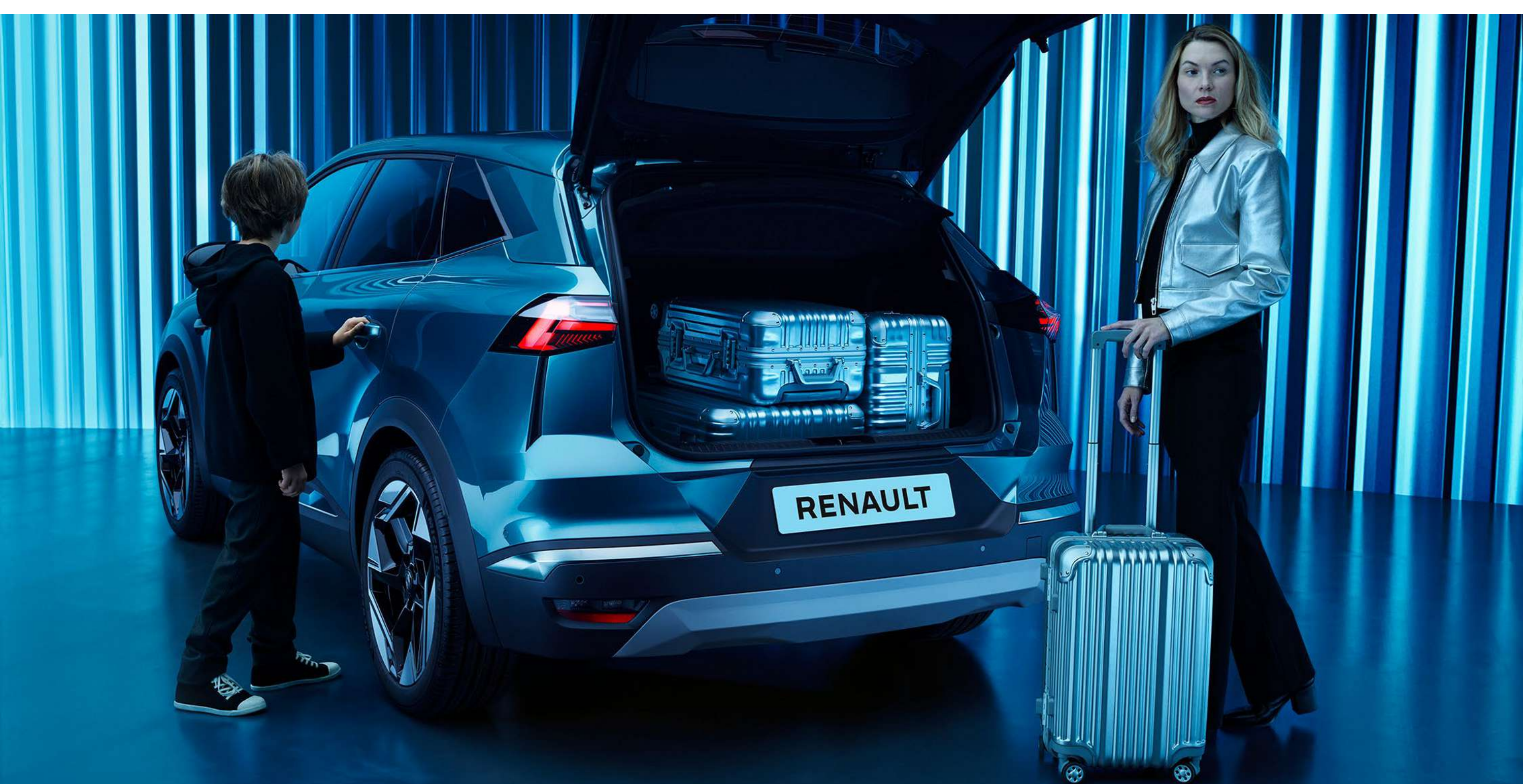

Save space in a flash. Thanks to the sliding rear bench seat with 16 cm of travel, the boot capacity is increased from 576 litres to 708 litres⁽³⁾.



(1) depending on version. (2) with the mild hybrid engine. (3) with the mild hybrid engine and bench seat fully forward.

05. driving pleasure

engines

FULL HYBRID E-TECH & mild hybrid

160 hp
full hybrid
engine

up to
80%
driving time in electric
mode⁽¹⁾

up to
60 km/h
in electric mode

up to
1000 km
of range⁽²⁾

from
4,3 L/100 km
of fuel consumption⁽³⁾

from
98 g/km
CO₂ emissions⁽³⁾



version shown not available in Ireland

With the new 160 hp full hybrid E-Tech and 140 hp mild hybrid engines, acceleration is smooth and dynamic, while optimising your fuel consumption. Silence, responsiveness, agility, whether you're driving in town or out on the road.



140 hp mild hybrid engine

First level of hybridisation to reduce fuel consumption while taking advantage of dynamic acceleration phases.



160 hp full hybrid E-Tech engine

In urban and suburban areas, enjoy fuel savings of up to 40%⁽⁴⁾; drive up to 80% of the time in electric mode and without any noise, while charging the battery when decelerating or braking.

(1) up to 80% electric driving in urban and suburban areas. Depending on the state of charge of the battery and driving style / Renault internal source 2023. (2) with a full tank of petrol according to WLTP data. (3) approval in progress. (4) for a full hybrid E-Tech engine compared with a mild hybrid auto engine, according to WLTP City protocol (utac & idiada source, September 2022).

detect, inform, guide

The "safety score" assesses your ability to drive safely by analysing information about speed, trajectory and safety distance as you drive. At the end of each trip, it displays your score from 0 to 100 to help you improve your driving.



The "safety coach" helps you to improve your driving by using the safety score and informs you in real time of the potential risks on your route, based on the surrounding data.

06. safety & security



29 advanced driving-assistance systems

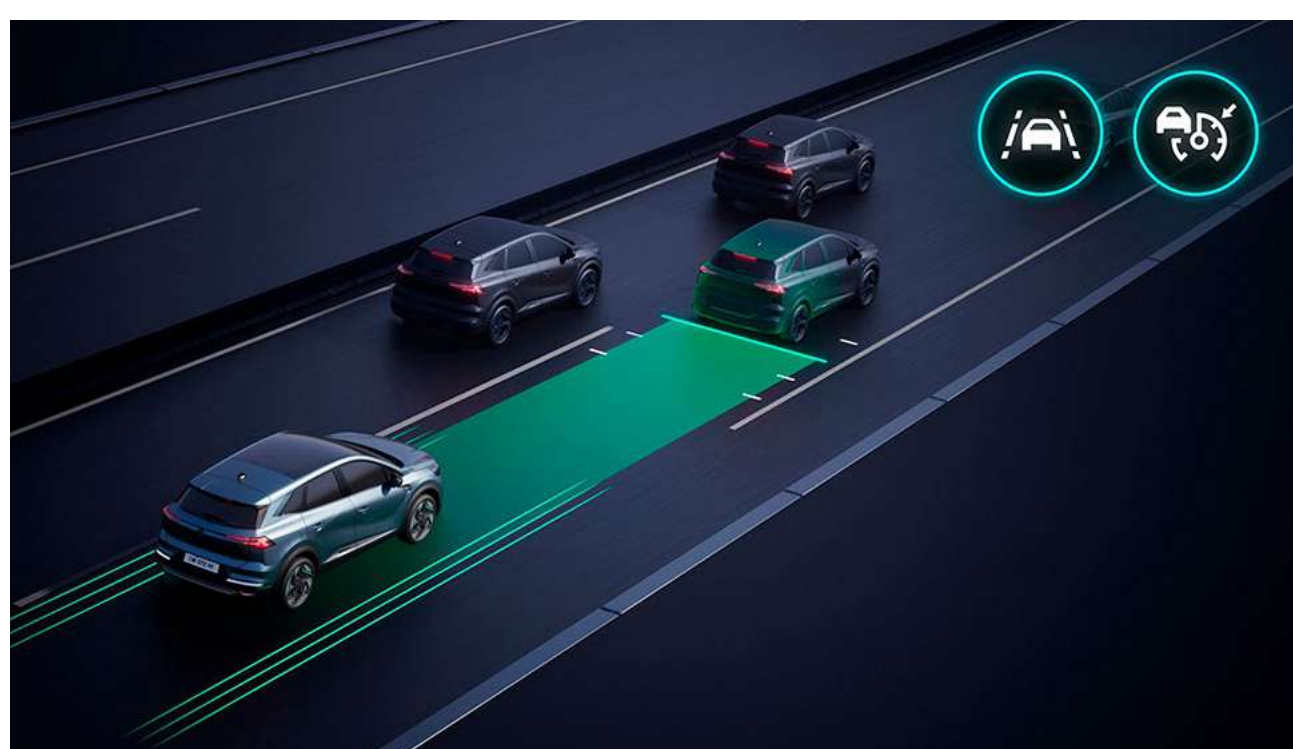

active driver assist

This system regulates your speed by taking the road environment into account, maintains safe distances and ensures you remain in lane. When traffic slows down, the vehicle stops and restarts automatically.

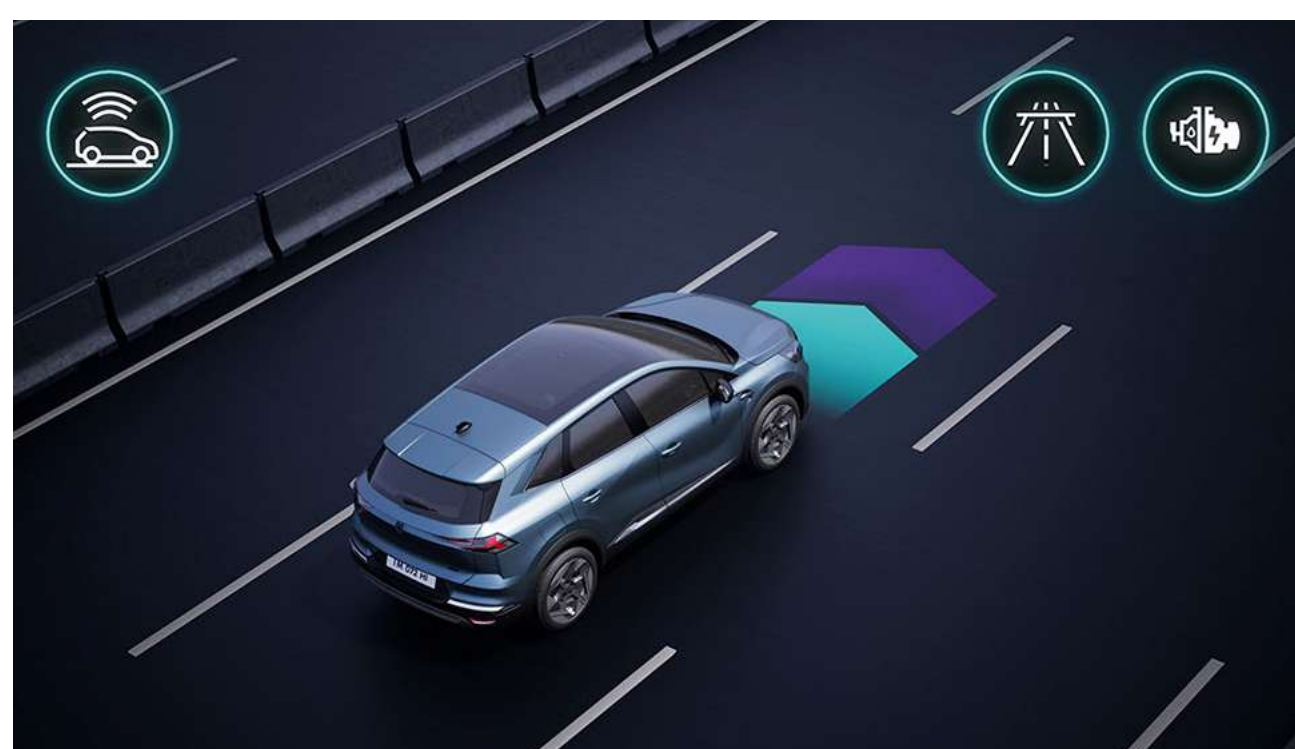

predictive hybrid driving

Your car anticipates combustion-engine, hybrid or 100% electric driving by continuously analysing your route to establish the time at which you shall drive through a town or whether you risk encountering a particular topography or a traffic jam. As a result, you improve the fuel consumption and performance of your vehicle.

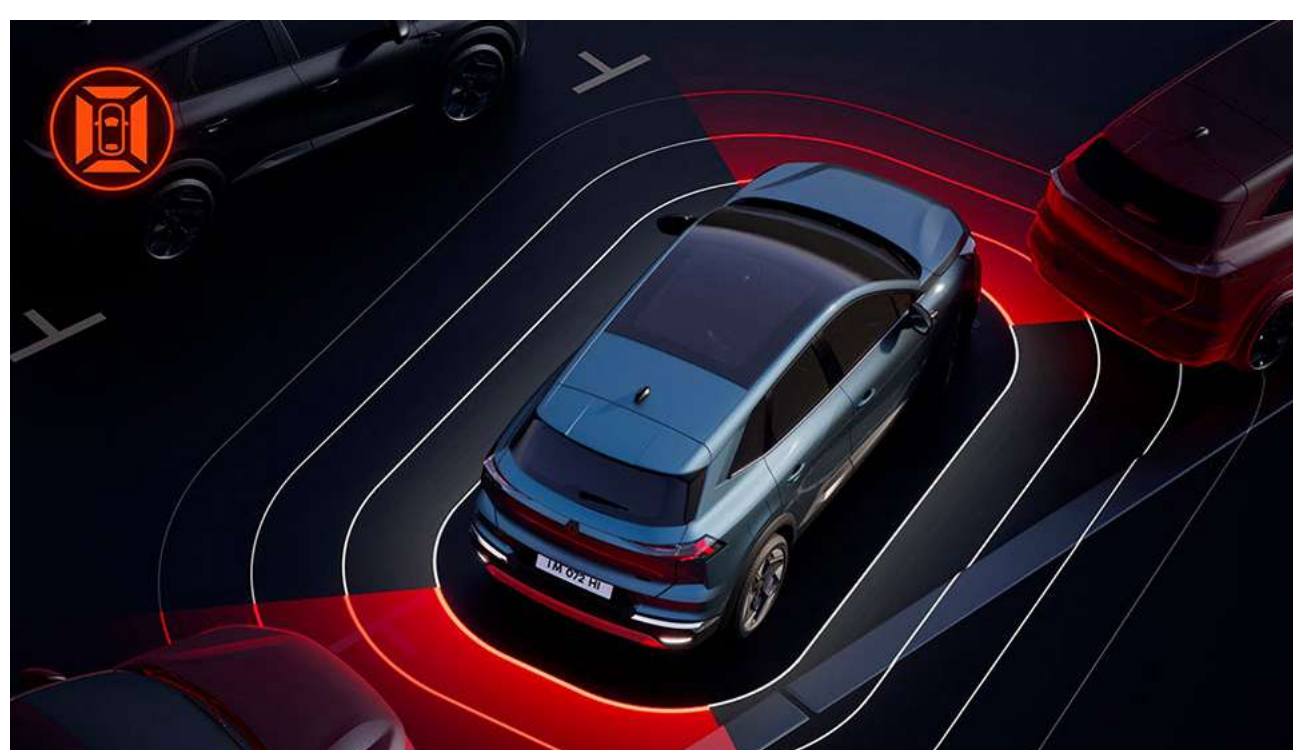

360°-view camera

The 4 cameras, whose images recreate the vehicle's direct environment 360° around it, allow you to perform your manoeuvres effortlessly.



rear automatic emergency braking system

This system detects obstacles at the rear and stops the vehicle automatically in the event of danger.



lane keeping assist

This system corrects the angle of the steering wheel, returning the vehicle to its lane unless you have indicated.



occupant safe exit alert

This system alerts you if a vehicle is approaching from the rear when you want to open the door.

driver assistance

- active driver assist
- hill start assist
- safe following distance warning
- predictive eco-driving assistant
- predictive hybrid driving
- speed limiter
- adaptive cruise control
- intelligent adaptive cruise control

park assist systems

- rear parking assist
- front parking assist
- side parking assist
- rear view camera
- 360° around view camera
- hands-free parking

safety assistance systems

- lane departure warning
- occupant safe exit alert
- lane keeping assist
- blind spot warning
- blind spot warning and lane departure prevention when overtaking
- rear parking space exit warning when reversing
- automatic switching between main-beam / dipped headlights
- rear detection with emergency trajectory correction
- front detection with emergency trajectory correction
- automatic emergency braking at intersections
- reverse automatic emergency braking system
- automatic urban and inter-urban emergency braking (with detection of cars, pedestrians and cyclists)
- traffic sign recognition with speed alert
- traffic sign recognition
- driver fatigue detection system

07. customisation

colours



mercury blue (mp)⁽¹⁾



silver grey (mp)



ceramic grey (mp)



diamond black (mp)



pearl white (p)



flame red (mp)



iron blue (mp)

free colour: flame red

p: pearlescent

mp: metallic paint

(1) not available on evolution and esprit Alpine versions.

photos not contractually binding

07. customisation

evolution



- metallic grey decorative upper strip
- 10.4" openR link: multimedia system with integrated radio
- 7" high-definition customisable digital driver instrumentation



embossed mottled grey fabric / black kario fabric with drake blue top-stitching



17" nymphéa wheel trims

07. customisation

techno



- granite grey decorative upper strip
- 10.2" high-definition customisable digital driver instrumentation
- 10.4" openR link: connected multimedia system with Google built-in⁽¹⁾



embossed marled black fabric / titanium
black refined textile with yellow
top-stitching



18" gravity alloy wheels

(1) Google, Google Play, Google Maps, Waze and other brand names are trademarks of Google LLC.

07. customisation

techno esprit Alpine & iconic esprit Alpine



- alpine marking with Alpine logo on front seats
- upper strip with brushed blue shaded finish
- heated steering wheel
- aluminium pedal unit



75% recycled fabric / titanium black refined textile with blue top-stitching



19" elixir alloy wheels

07. customisation

accessories



exterior customisation packs and premium side steps

Shape Renault Symbioz and accentuate its dynamism with the front and rear bumper skid plates and the door mirror shells⁽¹⁾ from the exterior customisation pack. With the premium side steps, enhance its design and easily access roof loading.



tool-free removable towbar and quickfix roof bars

Tow your equipment, leisure equipment or a boat in complete safety thanks to the range of tow bars specifically designed for Renault Symbioz. With the quickfix transverse roof bars, you can easily transport a bicycle rack or roof box.

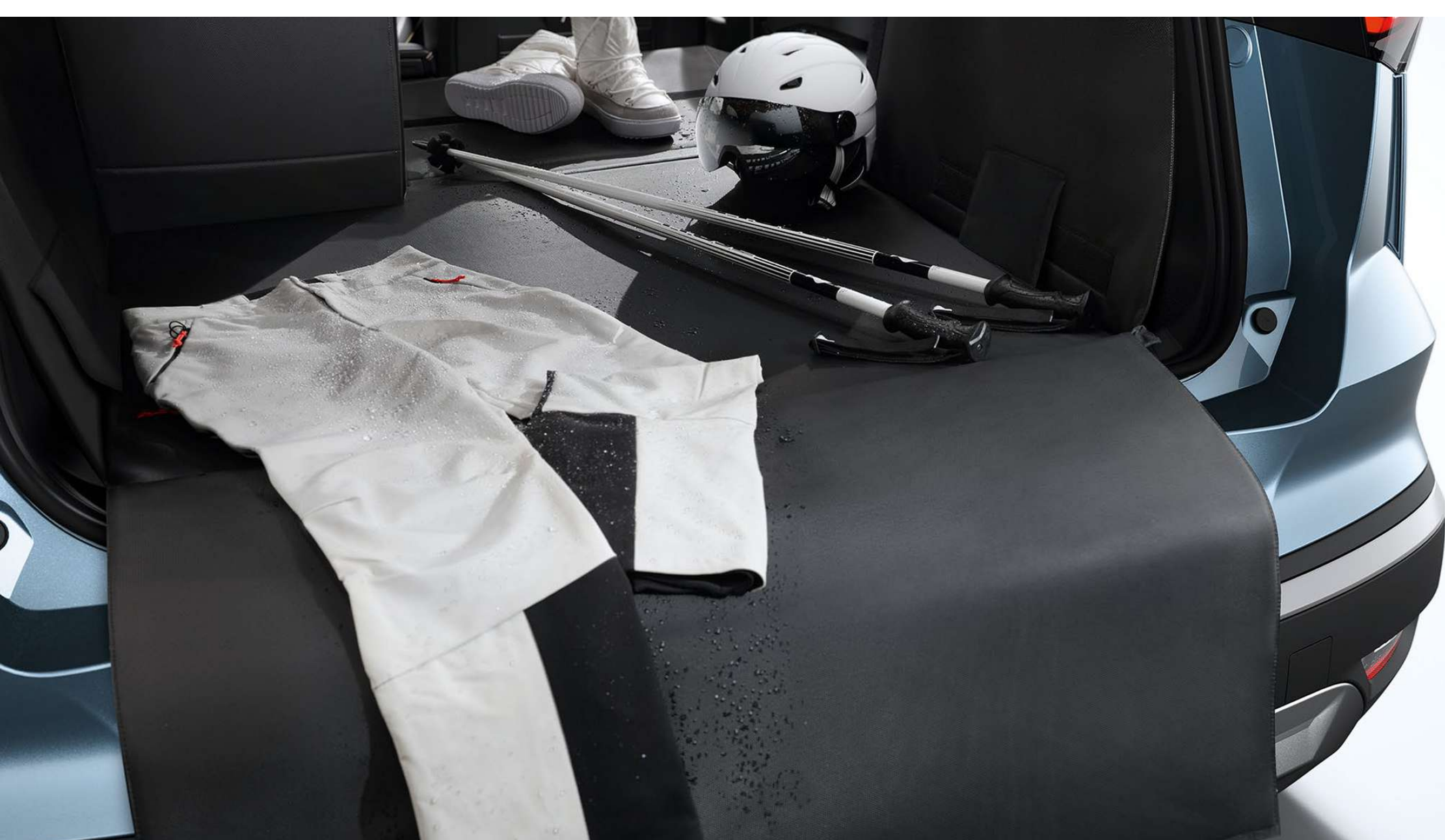

easyflex modular boot protection

Essential for protecting the boot of your vehicle and transporting bulky and dirty items. Compatible with both boot floor positions, it folds and unfolds easily and covers the entire loading area.



stainless steel boot sill and boot storage nets

The custom-made, robust stainless steel boot sill elegantly covers and protects the boot opening when loading items. Horizontal or vertical storage nets keep items secure during transport.



rear passenger accessories

Choose the Alcantara rear headrest cushion for your well-being, offering support and comfort. Transform the armrest into a stylish backpack for practical and stylish storage of your items. The multifunction organiser has a number of clever places to store all of your everyday items.

Version shown not available in Ireland.
(1) pearl grege and highland grey door mirror shells.

07. customisation

engines

| mild hybrid 140 | full hybrid E-Tech 160 |
|--|--|
| energy | |
| unleaded fuel (E10) | unleaded petrol (E10) + electric |
| max. power kW CEE (hp) / engine speed of (rpm) | |
| 103 (140 hp) | 116 (160 hp) |
| max. torque (Nm CEE) / engine speed of (rpm) | |
| 260 N.m from 1,750 to 3,500 | 170 N.m (internal combustion engine) + 205 N.m (electric motor) |
| battery | |
| type | |
| lithium-ion | lithium-ion |
| performance | |
| 0 - 100 km/h (s) | |
| 11.2 | 9.1 |
| mid-range acceleration: 80 km/h to 120 km/h (s) | |
| 7.7 | 7.9 |

dimensions and volumes

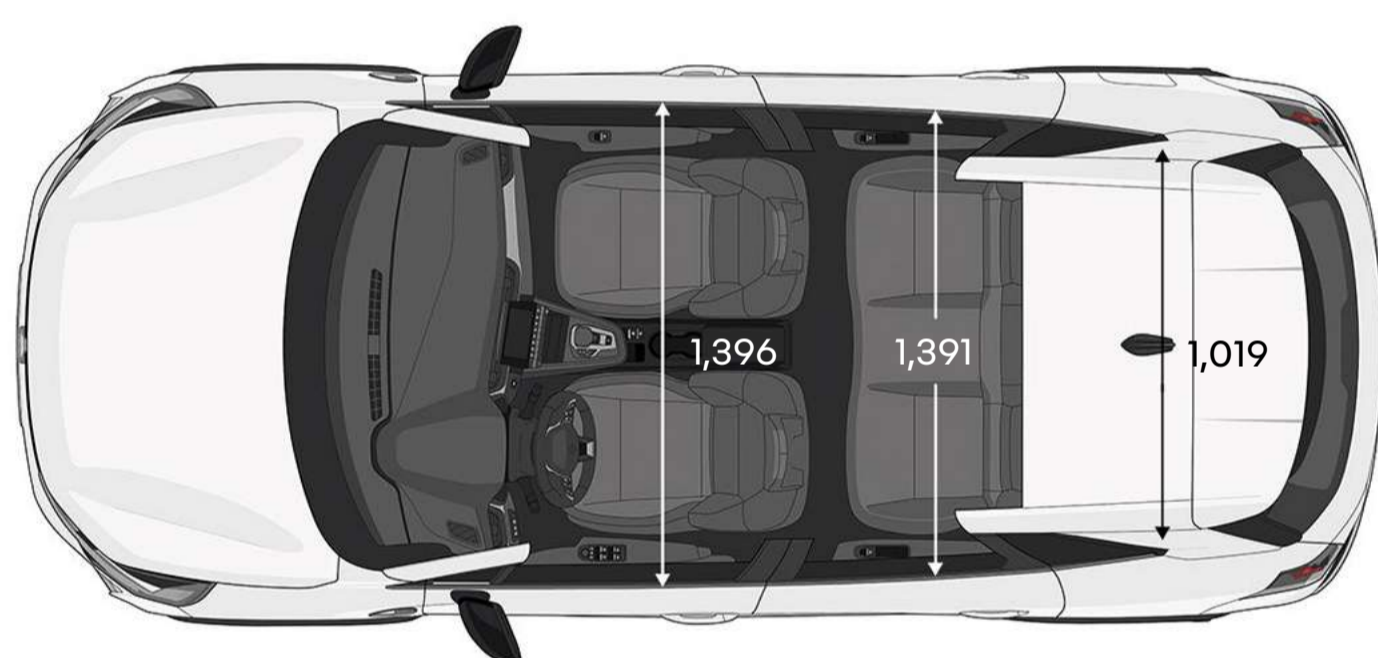
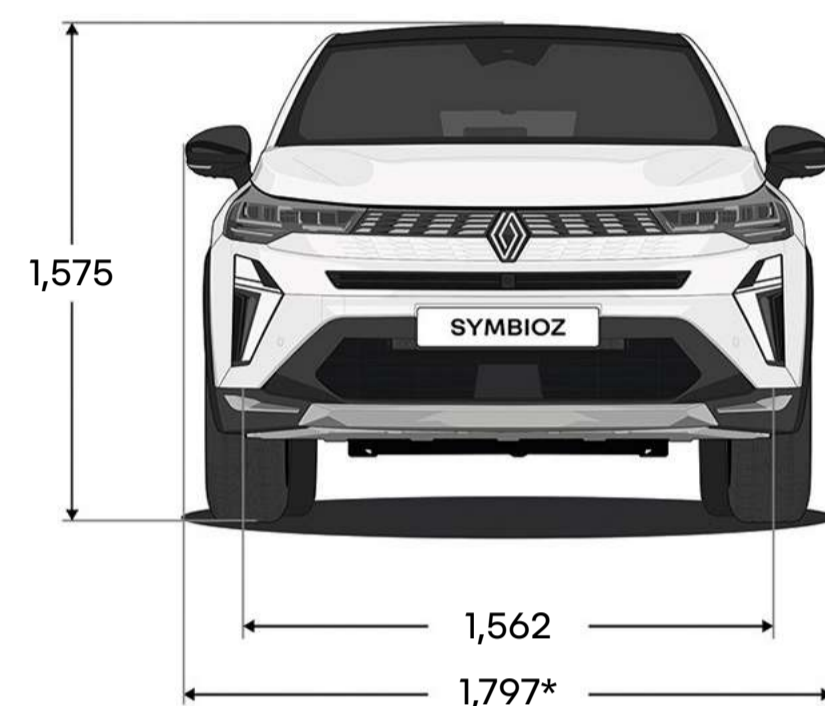
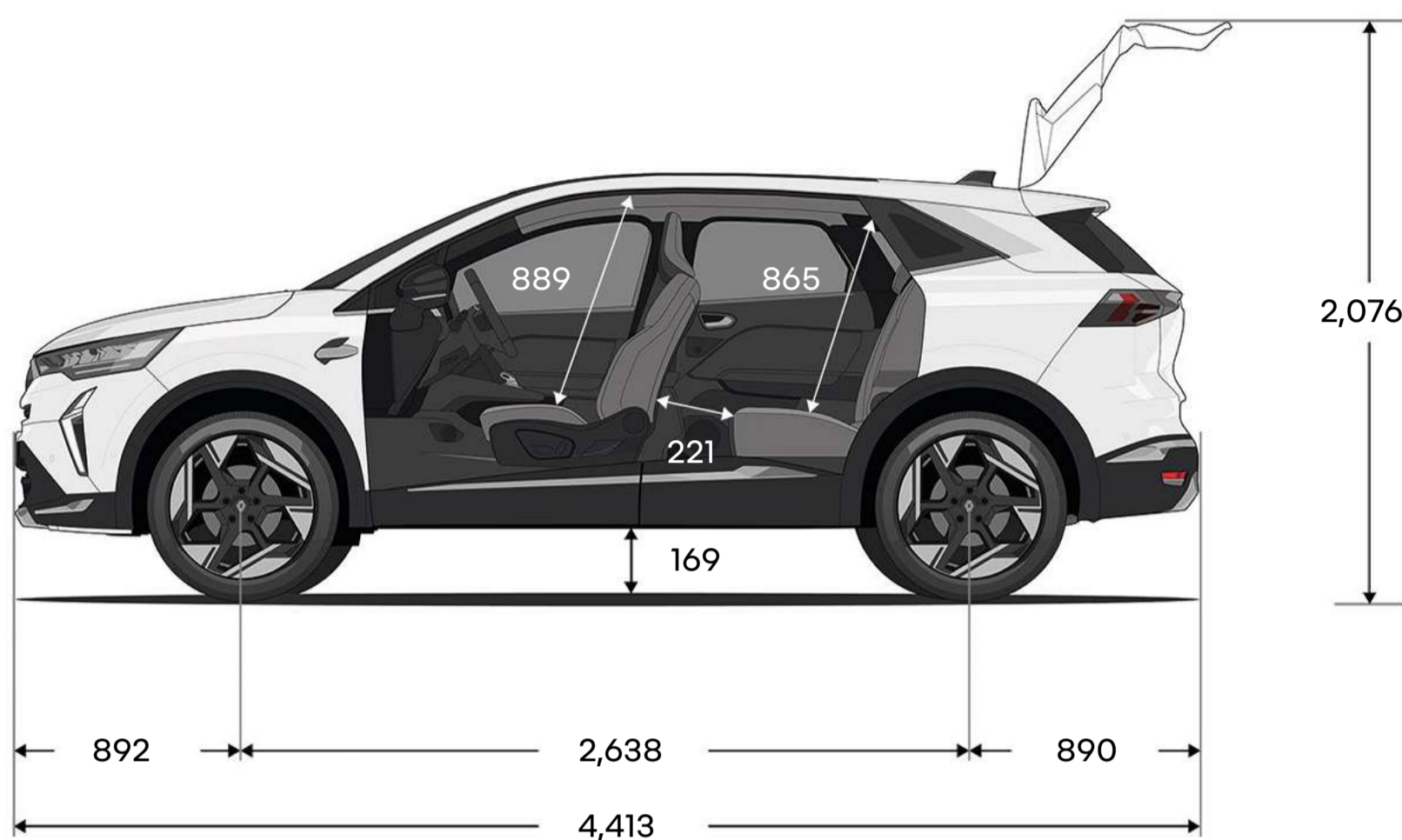

| boot volume (in litres) | mild hybrid | full hybrid E-Tech |
|---|-------------|--------------------|
| boot volume, bench seat in rear position | 576 | 492 |
| boot volume, bench seat in forward position | 708 | 624 |
| boot volume, bench seat folded down | 1,682 | 1,582 |

dimensions in (mm) * door mirrors folded.

the human first program is a comprehensive safety program developed by Renault in collaboration with researchers, experts and firefighters.

as road safety concerns all road users, whether pedestrians, cyclists or motorists, the human first program by Renault aims to:

1. prevent accidents by developing safety equipment and advanced driver-assistance and safety systems

up to 32 advanced driver-assistance systems / more than 60 safety features, up to 7 airbags, child seats (Isofix), Renault Fixe4sure solution / more than 2,000 safety-related patents filed since 1970

2. manage accidents once they have happened by drawing on innovations developed in collaboration with firefighters

QRescue / Fireman Access / more than 5,000 firefighters trained over 10 years in 20 countries worldwide / around 400 cars donated per year for their training

3. reduce the number of accidents and their severity by investing massively in R&D

safety score / safety coach / connected services / big data / artificial intelligence and cybersecurity systems



Every precaution has been taken to ensure that the contents of this brochure were accurate and up to date at the time of its release. This document has been created using pre-production and prototype models. In line with its policy of continuous product improvement, Renault reserves the right to modify the specifications, vehicles and accessories described and featured at any time. Any such modifications are communicated to Renault dealers as quickly as possible. Depending on the country of sale, versions may differ and some equipment may be unavailable (standard, optional or accessories). Please contact your local dealer for the latest information. For reasons to do with the medium, the colours featured in this document may differ slightly from those of the actual paintwork or interior trim. All rights reserved. Reproduction in any format and by any means of all or part of this brochure is prohibited without prior written authorisation from Renault.

Publicis - photo credits: © Akatre, Renault Marketing 3D-Commerce - July 2025.
Renault s.a.s, a French simplified joint stock company with a share capital of € 533,941,113.00 / 122-122 quai Le Gallo - 92100 Boulogne-Billancourt Cedex, France - registered on the Trade and Companies Registry (R.C.S.) of Nanterre (Trade & Companies Register) B 780 129 987 / Tel.: 0806 00 20 20.

Renault recommends  **Castrol**

